

HERRAMIENTAS HSK-T

HERRAMIENTAS HSK, A LA VANGUARDIA DEL
MECANIZADO DE ÚLTIMA GENERACIÓN



HERRAMIENTAS HSK-T

SISTEMA DE HERRAMIENTAS PARA TORNEADO PARA MÁQUINAS MULTI-TAREA

SISTEMA HSK-T

Sistema HSK diseñado para el torneado en máquinas multi-tarea que son compatibles con el tipo HSK-A (norma ISO: ISO 12164-1:2001).

El sistema HSK ha sido desarrollado por un consorcio de 17 fabricantes japoneses y que registraron en 2008 la norma ISO (ISO12164-3:2008) con el nombre HSK-T y, en 2013, en la norma JIS (JIS B6064-3).

POSICIONAMIENTO DEL FILO DE CORTE DE ALTA PRECISIÓN

El tipo HSK-T tiene una menor tolerancia entre el eje y la ranura del mango de la herramienta que el tipo HSK-A. Esto da como resultado una mayor precisión en la posición del filo de corte. Para el fresado pueden usarse herramientas convencionales de tipo HSK-A.

COMPATIBLE CON MÁQUINAS MULTI-TAREA Y CENTROS DE MECANIZADO

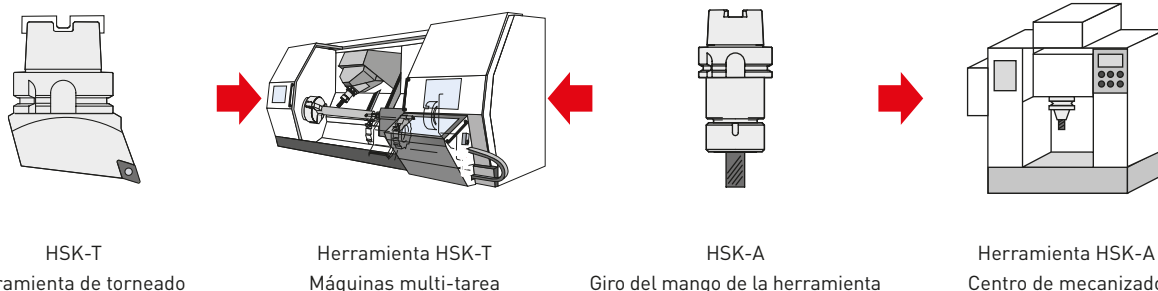

*** Nota:**

Longitud de cuello corta desde la brida con cuerpo grueso de la herramienta de torneado HSK-T, tal y como se muestra en la figura de la izquierda. Antes de montar, asegúrese, ya que existen máquinas que no se pueden montar dependiendo de las especificaciones ATC de la máquina multitarea (tipo HSK-A). Preste también atención a la interferencia con las herramientas circundantes.

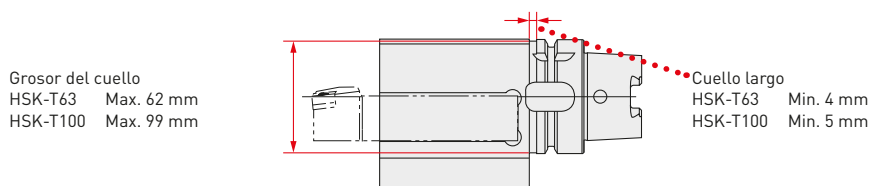

Herramienta de torneado HSK-T estándar (Ejemplo)

MEJORA EN LA TOLERANCIA DE LA RANURA

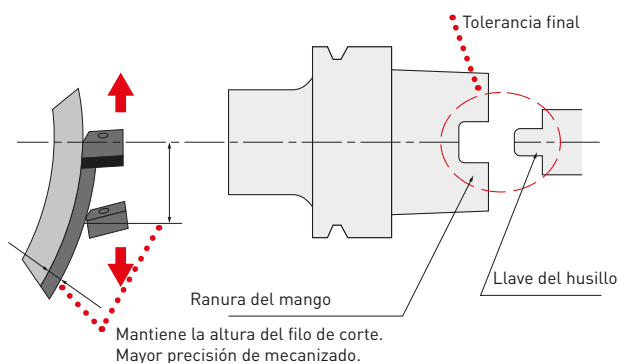

Comparación de tolerancia (Ejemplo)

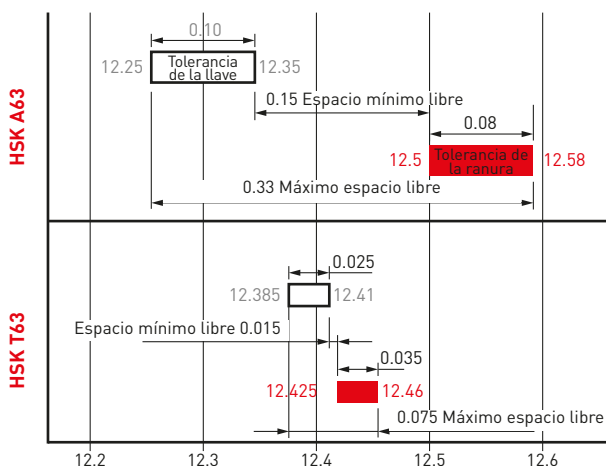

HERRAMIENTAS HSK-T

SISTEMA DE HERRAMIENTAS TIPO HSK-T DE GRAN PRECISIÓN Y RIGIDEZ, DESARROLLADO PARA USAR EN MÁQUINAS MULTI-TAREA

HERRAMIENTAS DE TIPO RECTO PARA USAR EN MÁQUINAS MULTI-TAREA

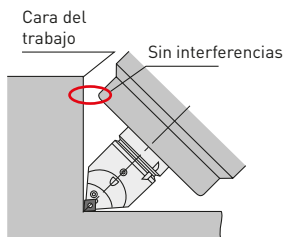

Evite interferencias con la pieza de trabajo mejorando la accesibilidad de la herramienta.

Al inclinar el eje B de la máquina (eje principal de la herramienta) con una interferencia de 45° entre el eje y el portaherramientas, se puede salvar la pieza de trabajo y el husillo.

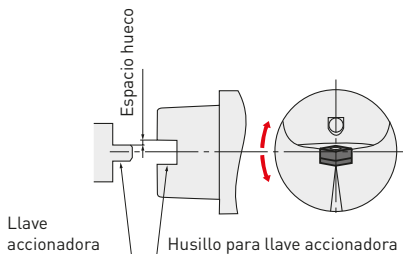

Mejore la altura del eje principal colocando el filo de corte en el centro del eje.

Pueden conseguirse mayor estabilidad y precisión ya que la altura del centro de línea del filo de corte no resulta afectada por el hueco entre el mandril y la cuña.

NUEVA SERIE CON DOBLE SUJECIÓN

El mecanismo de doble sujeción ofrece una gran rigidez, precisión y fiabilidad que garantiza una segura sujeción de la placa. Es adecuado para materiales difíciles de mecanizar, tales como, inoxidables y termorresistentes.



Herramienta para torneado y refrentado



De tipo recto para torneado y refrentar



Para torneado, refrentar y mandrinar

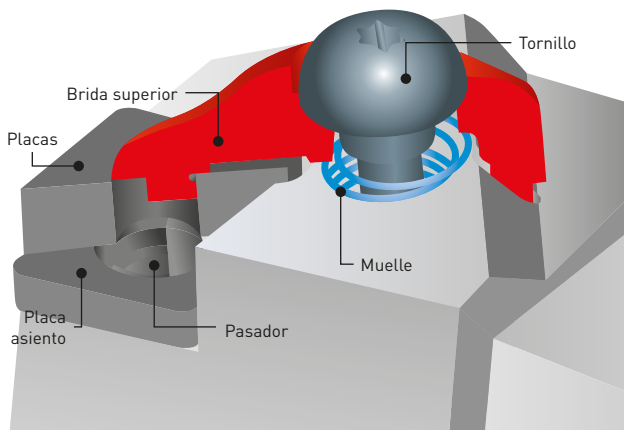

HERRAMIENTAS HSK-T

HERRAMIENTA 3 EN 1 PARA EL PROCESO DE SUSTITUCIÓN DE HERRAMIENTAS

EN UNA MISMA HERRAMIENTA PUEDEN INSTALARSE 3 PLACAS PARA TORNEADO DE LA MISMA GEOMETRÍA

- Puede instalarse el mismo tipo de placas para un cambio rápido de herramientas y sus repuestos.
- Pueden instalarse diferentes tipos de placas para diferentes aplicaciones (desbastado, semiacabado y acabado)
- Puede instalarse placas de diferentes calidades para realizar diferentes piezas.



TAMAÑO HSK-T100 PARA PIEZAS DE GRANDES TRABAJOS

LAS DIMENSIONES DEL MANGO SON MÁS GRANDES PARA UNA ALTA EFICIENCIA



Tipo mango cuadrado



Barra de mandrinar/Tipo Broca



Casquillo

UNA ÚNICA HERRAMIENTA PUEDE UTILIZARSE CON DIFERENTES HERRAMIENTAS

- Disponible para usar con herramientas JIS B4126 (ISO 5610) 32 x 32 y 32 x 25.
- Es posible adaptar una herramienta 25 x 25 usando una placa de 7 mm.

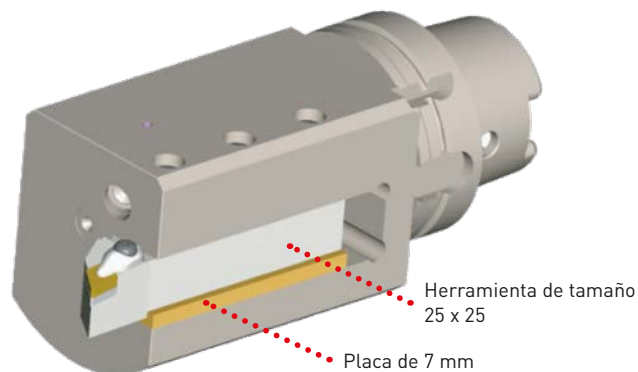

1. Placa no suministrada.

HERRAMIENTAS HSK-T

CLASIFICACIÓN HERRAMIENTAS HSK-T

TORNEADO EXTERIOR - REFRENTADO - COPIADO

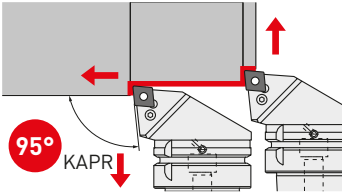
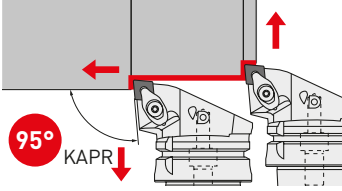
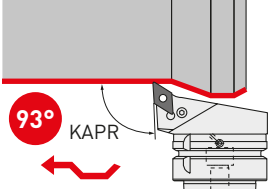
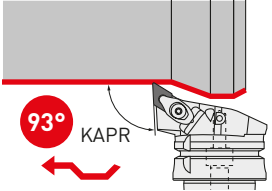
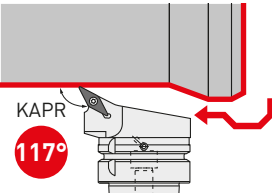
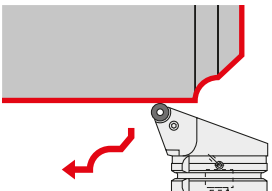
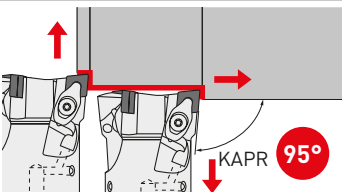
Referencia	Geometría	
H63TH-PCLNR/L-DX12		10
H63TH-DCLNR/L-DX12		11
H63TH-PDJNR/L-DX15		16
H63TH-DDJNR/L-DX15		17
H63TH-SVPBR/L-DX16		24
H63TH-PRGCR/L-DX12		21
H63TH-DCLNL-L12-3		14

HERRAMIENTAS HSK-T – CLASIFICACIÓN HERRAMIENTAS HSK-T

TORNEADO EXTERIOR – REFRENTADO – COPIADO

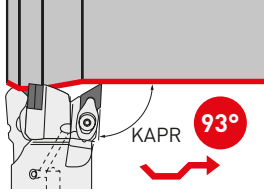
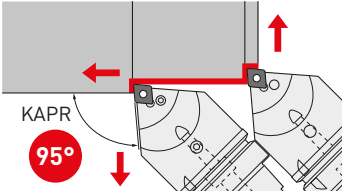
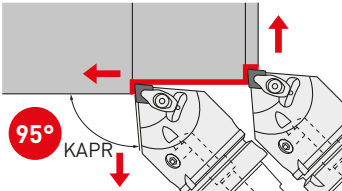
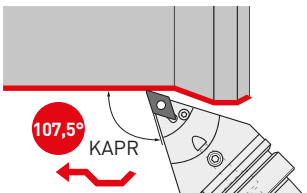
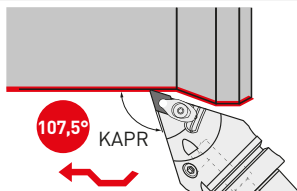
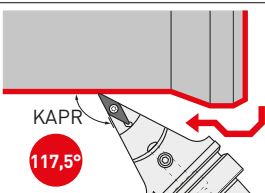
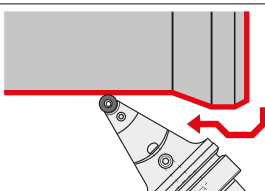
Referencia	Geometría	
H63TH-DDJNL-L15-3		20
H63TH-PCMNN-H/L12		12
H63TH-DCMNN-H/L12		13
H63TH-PDNNN-H/L15		18
H63TH-DDNNN-H/L15		19
H63TH-SVBN-H/L16		25
H63TH-PRDCN-H/L12		22

HERRAMIENTAS HSK-T – CLASIFICACIÓN HERRAMIENTAS HSK-T

Referencia	Geometría	
TORNEADO EXTERIOR – REFRENTADO – MANDRINADO		
H63TH-A25KDCLNR/L12/ H63TH-A32LDCLNR/L12		15
RANURADO		
H63TH-MGHR/L-DX43		27
ROSCADO		
H63TH-MMTER-DX16		30
H63TH-MMTENR-H/L16		31
H63TH-MTHR/L-DX43		33

HERRAMIENTAS HSK-T – CLASIFICACIÓN HERRAMIENTAS HSK-T

Referencia

Herramienta



HERRAMIENTAS DE TORNEADO EXTERIOR

H63TH-EV2525R/L-112



37

H100TH-EV3232R/L-180



38

H63TH-EN2525R/L-115*1



39

H100TH-EN3232R/L-130*1



40

H63TH-EV2020R/L-105-3



41

HERRAMIENTAS HSK-T – CLASIFICACIÓN HERRAMIENTAS HSK-T

Referencia	Herramienta	
BARRAS DE MANDRINAR		
H63TH-B○○-○○		42
H100TH-B○○-○○○		43
SL32○○-90*2		44

3/3

1. El HSK63A lleva incorporada la cánula de refrigerante.

*2 Mitsubishi Materials tiene licencia para la producción y distribución de estas herramientas de MORI SEIKI CO., LTD bajo la patente N° 3720202.

*3 El manguito SL32○○-90 es para usar sólo con H100TH-B32-135.

PCLN

TORNEADO EXTERIOR – REFRENTADO

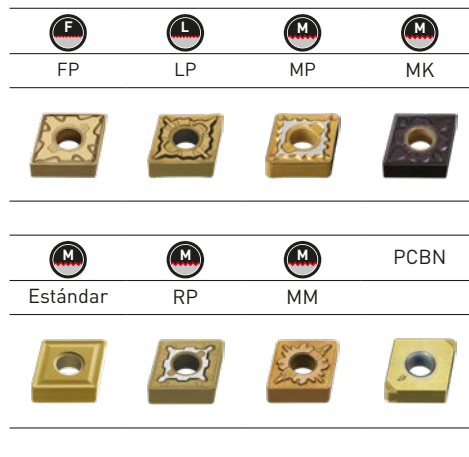
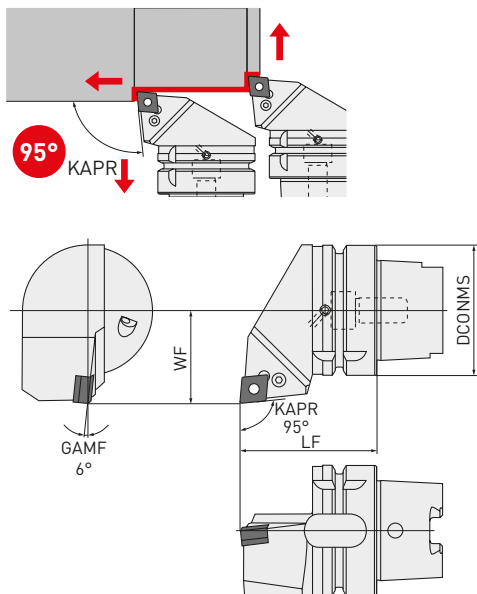

Se muestra el portaherramientas a mano derecha.





Referencia	Stock	Mano	DCONMS	LF	WF	WT*2	Placas
H63TH-PCLNR-DX12*	●	R	63	65	45	1.3	CN0A/CN0G/CN0M 120400
H63TH-PCLNL-DX12*	●	L	63	65	45	1.3	

1/1

1. Las dimensiones que se muestran son con placas de radio 0.8.



REPUESTOS

Placas					
	Placa base	Pasador de asiento	Palanca	Tornillo	Llave
CN0A/CN0G/CN0M	LLSCN42	LLP14	LLCL14	LLCS108	HKY30R

* Las Herramientas marcadas en la tabla, no se pueden fijar en la Mazak INTEGREX I, J serie.

*1 Par de fijación (N • m): LLCS108 = 3.3

*2 WT: Peso de la herramienta

DCLN

TORNEADO EXTERIOR – REFRENTADO TIPO DOBLE FIJACIÓN

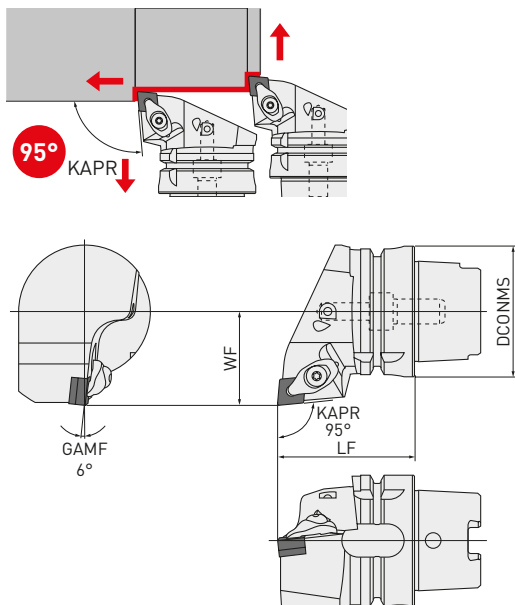

Se muestra el portaherramientas a mano derecha.

Referencia	Stock	Mano	DCONMS	LF	WF	WT*2	Placas
H63TH-DCLNR-DX12*	●	R	63	65	45	1.3	CN0A/CN0G/CN0M 120400
H63TH-DCLNL-DX12*	●	L	63	65	45	1.3	

1/1

1. Las dimensiones que se muestran son con placas de radio 0.8.



REPUESTOS

Placas	Placa base	Pasador de asiento	Brida superior	Muelle	Tornillo	Llave
CN0A/CN0G/CN0M	LLSCN42	LLP14	DCK2613	DCS1	DC0621T	TKY20F

* Las Herramientas marcadas en la tabla, no se pueden fijar en la Mazak INTEGREX I, J serie.

*1 Par de fijación (N • m): DC0621T = 5.0

*2 WT: Peso de la herramienta

PCMN

TORNEADO EXTERIOR – REFRENTADO

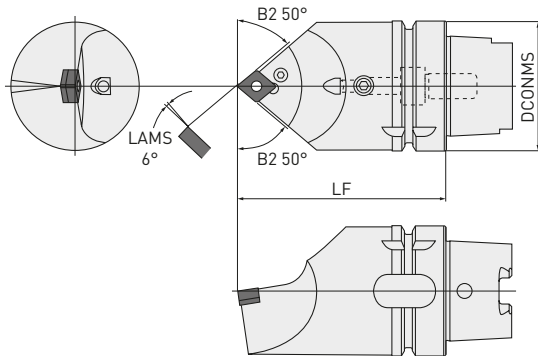
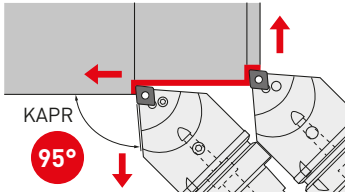







Referencia	Stock	DCONMS	LF	WT*2	Placas
H63TH-PCMNN-H12	●	63	100	1.7	CN0A/CN0G/CN0M 120400
H63TH-PCMNN-L12	●	63	140	2.7	

1/1

1. Las dimensiones que se muestran son con placas de radio 0.8.



REPUESTOS

Placas	 Placa base	 Pasador de asiento	 Palanca	 Tornillo*1	 Tapón	 Llave
CN0A/CN0G/CN0M	LLSCN42	LLP14	LLCL14	LLCS108	HGM-PT1/8	HKY30R

*1 Par de fijación (N • m): LLCS108 = 3.3

*2 WT: Peso de la herramienta

DCMNN

TORNEADO EXTERIOR – REFRENTADO TIPO DOBLE FIJACIÓN

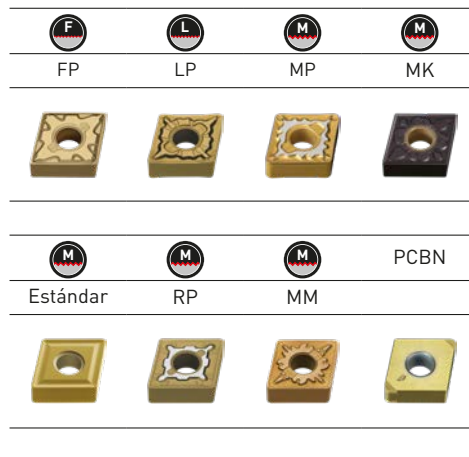
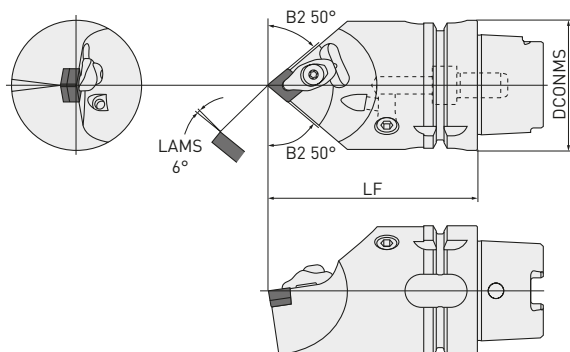
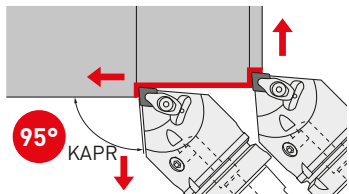

Referencia	Stock	DCONMS	LF	WT*2	Placas
H63TH-DCMNN-H12	●	63	100	1.7	CN0A/CN0G/CN0M 120400
H63TH-DCMNN-L12	●	63	140	2.7	

1/1

1. Las dimensiones que se muestran son con placas de radio 0.8.



REPUESTOS

Placas	Placa base	Pasador de asiento	Brida superior	Muelle	Tornillo	Llave
CN0A/CN0G/CN0M	LLSCN42	LLP14	DCK2613	DCS1	DC0621T	TKY20F

*1 Par de fijación (N • m): DC0621T = 5.0

*2 WT: Peso de la herramienta

DCLN

TORNEADO EXTERIOR – REFRENTADO TIPO DOBLE FIJACIÓN

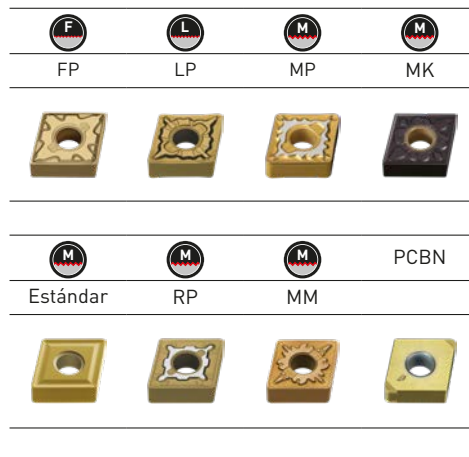
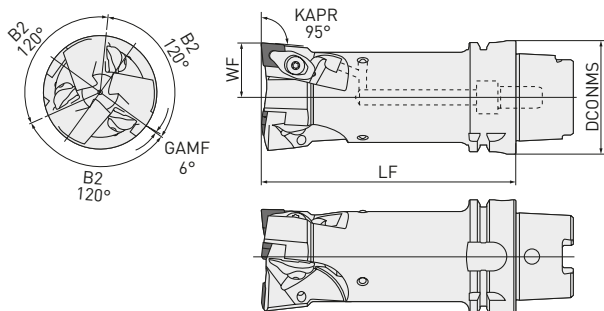
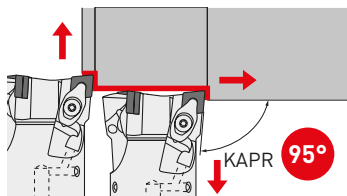

Solo herramienta a mano izquierda.

Referencia	Stock	DCONMS	LF	WF	WT*2	Placas
H63TH-DCLNL-L12-3	●	63	140	30	2.2	CN◊A/CN◊G/CN◊M 1204◊◊

1/1

1. Las dimensiones que se muestran son con placas de radio 0.8.



REPUESTOS

Placas						
	Placa base	Pasador de asiento	Brida superior	Muelle	Tornillo	Llave
CN◊A/CN◊G/CN◊M	LLSCN42	LLP14	DCK2613	DCS1	DC0621T	TKY20F

*1 Par de fijación (N • m): DC0621T = 5.0

*2 WT: Peso de la herramienta

DCLN

TORNEADO EXTERIOR – REFRENTADO – MANDRINADO TIPO DOBLE FIJACIÓN

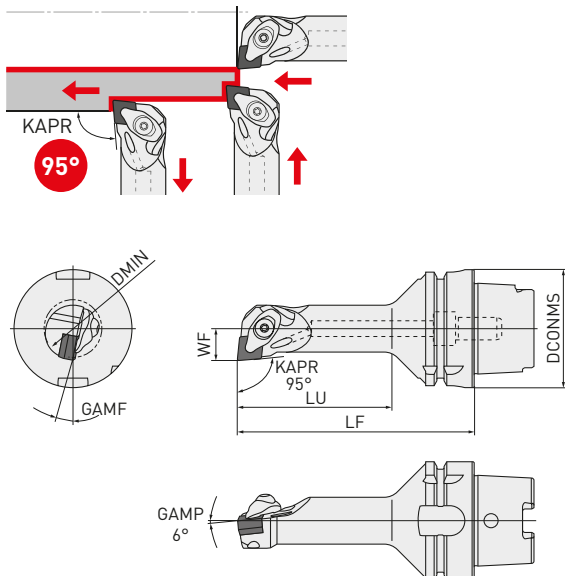

Se muestra el portaherramientas a mano derecha.

Referencia	Stock	Mano	DCONMS	LF	LU	WF	GAMF	DMIN	WT*2	Placas
H63TH-A25KDCLNR12	●	R	63	125	82	17	11°	32	1.1	CNOA/CNOG/CNOM 120400
H63TH-A25KDCLNL12	●	L	63	125	82	17	11°	32	1.1	
H63TH-A32LDCLNR12	●	R	63	125	100	22	13°	40	1.4	
H63TH-A32LDCLNL12	●	L	63	125	100	22	13°	40	1.4	

1/1

1. Las dimensiones que se muestran son con placas de radio 0.8.



REPUESTOS

Placas						
	Placa base	Pasador de asiento	Brida superior	Muelle	Tornillo	Llave
CNOA/CNOG/CNOM	LLSCN42	LLP14	DCK2613	DCS1	DC0621T	TKY20F

*1 Par de fijación (N • m): DC0621T = 5.0

*2 WT: Peso de la herramienta

PDJN

TORNEADO EXTERIOR – COPIADO

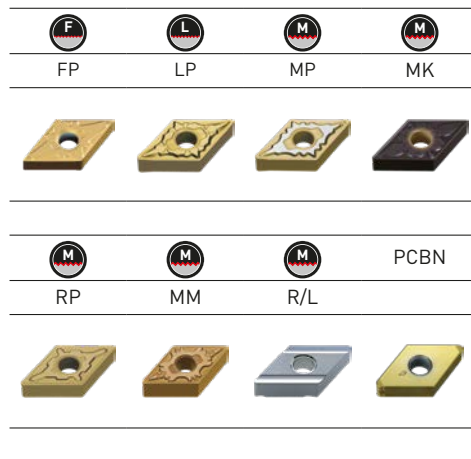
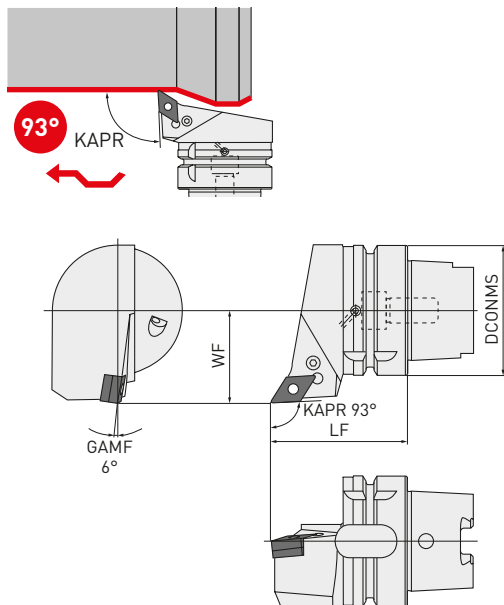

Se muestra el portaherramientas a mano derecha.





Referencia	Stock	DCONMS	LF	WF	WT* ³	Placas
H63TH-PDJNR-DX15*	●	63	65	45	1.2	DN [○] A/DN [○] G/DN [○] M/DNMX 1504 [○] ○
H63TH-PDJNL-DX15*	●	63	65	45	1.2	

1/1

1. Las dimensiones que se muestran son con placas de radio 0.8.



REPUESTOS

Placas	 *2			 *1	
	Placa base	Pasador de asiento	Palanca	Tornillo	Llave
DN [○] A/DN [○] G/DN [○] M/DNMX	LLSDN43 (LLSDN42)	LLP14	LLCL24	LLCS108	HKY30R

* Las Herramientas marcadas en la tabla, no se pueden fijar en la Mazak INTEGREX I, J serie.

*1 Par de fijación (N • m): LLCS108 = 3.3

*2 Utilizar placa de asiento LLSDN42 con placas de 6.35 mm de espesor. Cuando se utilicen éstas, la placa de asiento debe pedirse aparte.

*3 WT: Peso de la herramienta

DDJN

TORNEADO EXTERIOR – COPIADO TIPO DOBLE FIJACIÓN

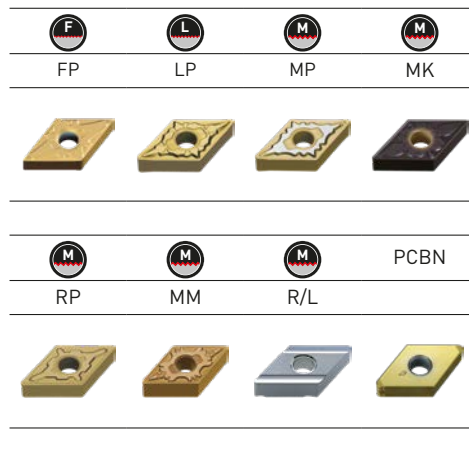
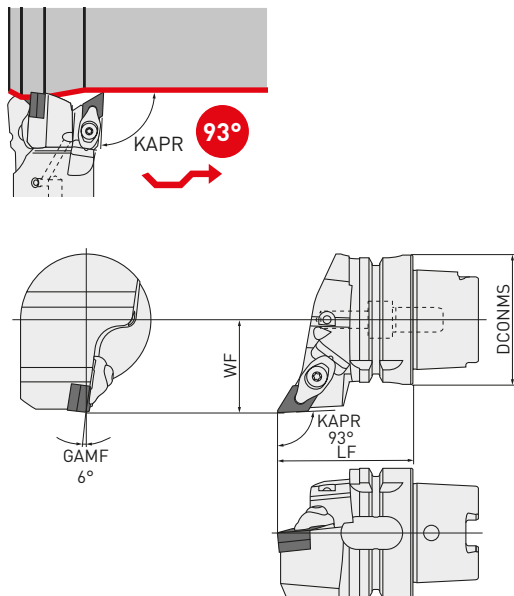

Se muestra el portaherramientas a mano derecha.

Referencia	Stock	DCONMS	LF	WF	WT* ³	Placas
H63TH-DDJNR-DX15*	●	63	65	45	1.2	DN [○] A/DN [○] G/DN [○] M/DNMX 1504 [○] ○
H63TH-DDJNL-DX15*	●	63	65	45	1.2	

1/1

1. Las dimensiones que se muestran son con placas de radio 0.8.



REPUESTOS

Placas	 * ²				 * ¹	
	Placa base	Pasador de asiento	Brida superior	Muelle	Tornillo	Llave
DN [○] A/DN [○] G/DN [○] M	LLSDN43 (LLSDN42)	LLP24	DCK2613	DCS1	DC0621T	TKY20F

*¹ Par de fijación (N • m): DC0621T = 5.0

*² Utilizar placa de asiento LLSDN42 con placas de 6.35 mm de espesor. Cuando se utilicen éstas, la placa de asiento debe pedirse aparte.

*³ WT: Peso de la herramienta

PDNN

TORNEADO EXTERIOR – COPIADO

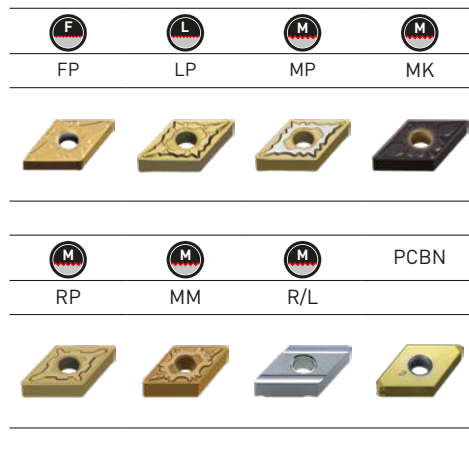
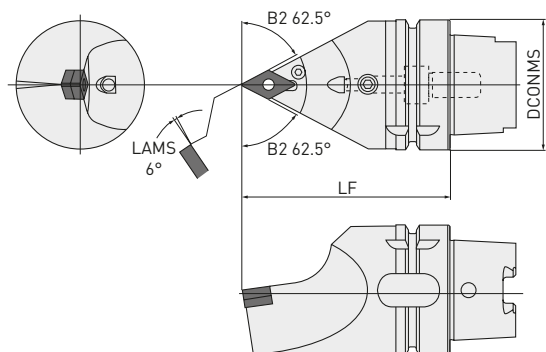
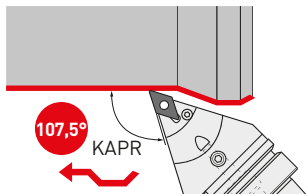

Referencia	Stock	DCONMS	LF	WT*3	Placas
H63TH-PDNNN-H15	●	63	100	1.6	DN \circ A/DN \circ G/DN \circ M 1504 \circ
H63TH-PDNNN-L15	●	63	140	2.5	

1/1

1. Las dimensiones que se muestran son con placas de radio 0.8.



REPUESTOS

Placas	*2	Pasador de asiento	Palanca	Tornillo *1	Tapón	Llave
DN \circ A/DN \circ G/DN \circ M	LLSDN43 (LLSDN42)	LLP14	LLCL24	LLCS108	HGM-PT1/8	HKY30R

*1 Par de fijación (N • m): LLCS108 = 3.3

*2 Utilizar placa de asiento LLSDN42 con placas de 6.35 mm de espesor. Cuando se utilicen éstas, la placa de asiento debe pedirse aparte.

*3 WT: Peso de la herramienta

DDNN

TORNEADO EXTERIOR – COPIADO TIPO DOBLE FIJACIÓN

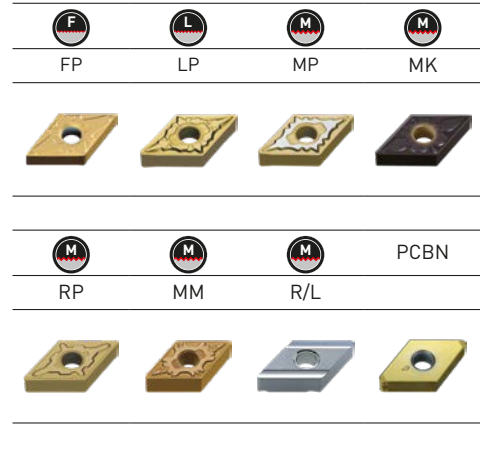
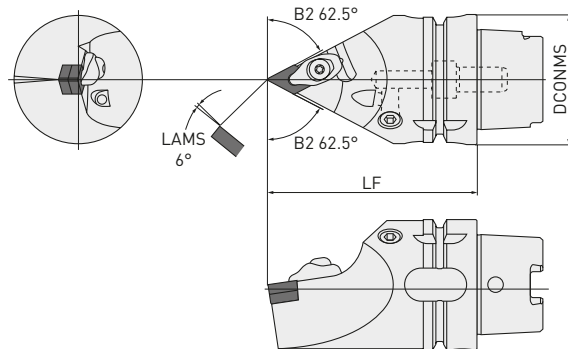
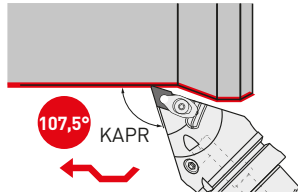





Referencia	Stock	DCONMS	LF	WT* ³	Placas
H63TH-DDNNN-H15	●	63	100	1.6	DN \odot A/DN \odot G/DN \odot M 1504 $\odot\odot$
H63TH-DDNNN-L15	●	63	140	2.5	

1/1

1. Las dimensiones que se muestran son con placas de radio 0.8.



REPUESTOS

Placas	 * ²				 * ¹	
	Placa base	Pasador de asiento	Brida superior	Muelle	Tornillo	Llave
DN \odot A/DN \odot G/DN \odot M	LLSDN43 (LLSDN42)	LLP24	DCK2613	DCS1	DC0621T	TKY20F

*¹ Par de fijación (N • m): DC0621T = 5.0

*² Utilizar placa de asiento LLSDN42 con placas de 6.35 mm de espesor. Cuando se utilicen éstas, la placa de asiento debe pedirse aparte.

*³ WT: Peso de la herramienta

DDJN

TORNEADO EXTERIOR – REFRENTADO TIPO DOBLE FIJACIÓN

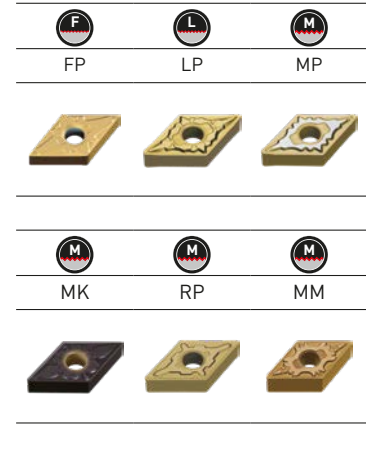
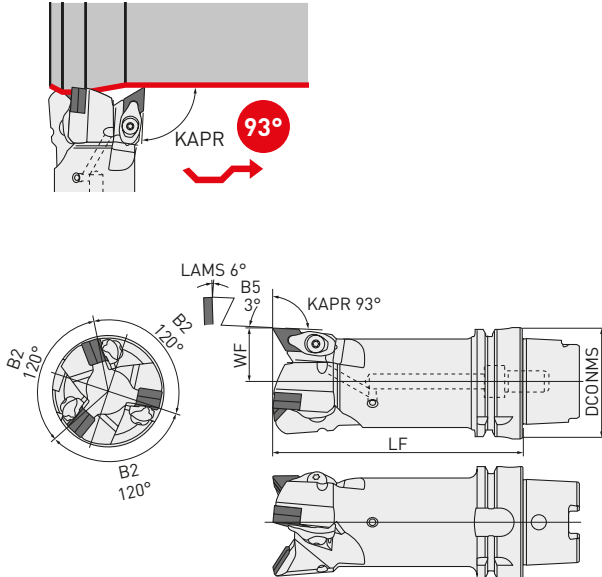

Solo herramienta a mano izquierda.







Referencia	Stock	DCONMS	LF	WF	WT* ²	Placas
H63TH-DDJNL-L15-3	●	63	140	30	2.2	DN [○] A/DN [○] G/DN [○] M/DN [○] MX 1504 [○] ○

1/1

1. Las dimensiones que se muestran son con placas de radio 0.8.



REPUESTOS

Placas	 * ²				 * ¹	
	Placa base	Pasador de asiento	Brida superior	Muelle	Tornillo	Llave
DN [○] A/DN [○] G/DN [○] M/DN [○] MX	LLSDN43 (LLSDN42)	LLP24	DCK2613	DCS1	DC0621T	TKY20F

*¹ Par de fijación (N • m): DC0621T = 5.0

*² Utilizar placa de asiento LLSDN42 con placas de 6.35 mm de espesor. Cuando se utilicen éstas, la placa de asiento debe pedirse aparte.

*³ WT: Peso de la herramienta

PRGC

TORNEADO EXTERIOR – REFRENTADO – COPIADO

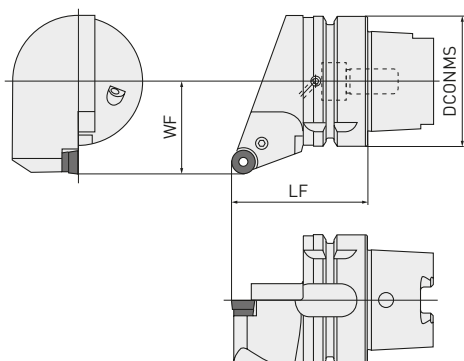
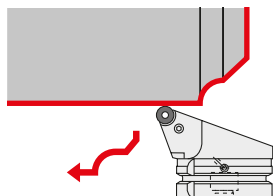





Referencia	Stock	DCONMS	LF	WF	WT* ²	Placas
H63TH-PRGCR-DX12*	●	63	65	45	1.2	RCMX 1204M0
H63TH-PRGCL-DX12*	●	63	65	45	1.2	

1/1



REPUESTOS

Placas					
	Placa base	Pasador de asiento	Palanca	Tornillo	Llave
RCMX	LLSRN123	LLP13	LLCL112	LLCS106	HKY25R

* Las Herramientas marcadas en la tabla, no se pueden fijar en la Mazak INTEGREX I, J serie.

*¹ Par de fijación (N • m): LLCS106 = 2.2

*² WT: Peso de la herramienta

PRDC

TORNEADO EXTERIOR – REFRENTADO – COPIADO

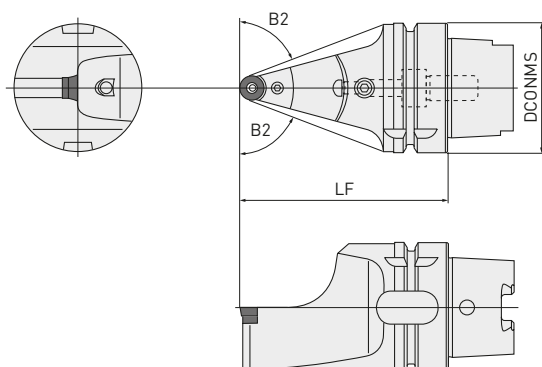
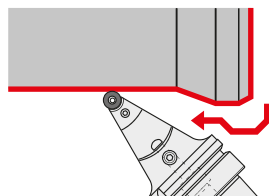





Referencia	Stock	DCONMS	LF	B2	WT* ²	Placas
H63TH-PRDCN-H12	●	63	100	69°	1.4	RCMX 1204M0
H63TH-PRDCN-L12	●	63	140	75°	2.3	

1/1



REPUESTOS

Placas						
	Placa base	Pasador de asiento	Palanca	Tornillo	Tapón	Llave
RCMX	LLSRN123	LLP13	LLCL112	LLCS106	HGM-PT1/8	HKY25R



* Las Herramientas marcadas en la tabla, no se pueden fijar en la Mazak INTEGREX I, J serie.

*¹ Par de fijación (N • m): LLCS106 = 2.2

*² WT: Peso de la herramienta

CONDICIONES DE CORTE RECOMENDADAS

PRGC / PRDC

	Material	Dureza		Calidad		Vc
P	Acero dulce	≤180HB	M	MC6115	Estándar	245 – 440
	Acero al carbono, Acero aleado	180 – 350HB	M	MC6115	Estándar	200 – 300
M	Acero Inoxidable	≤200HB	M	US735	Estándar	70 – 130

1/1

SVPB

REFRENTADO – COPIADO

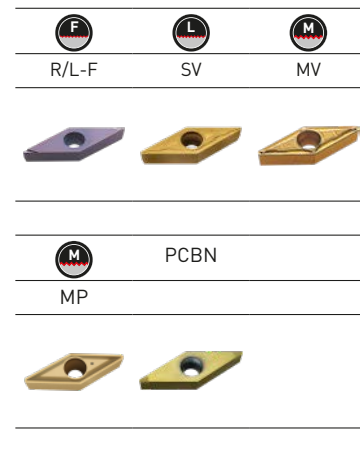
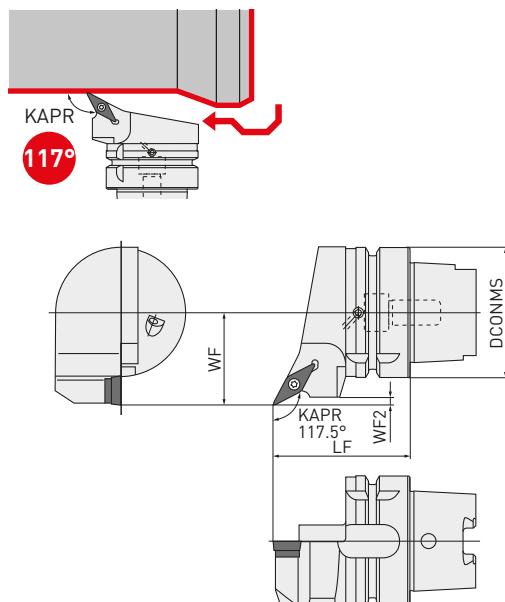

Se muestra el portaherramientas a mano derecha.





Referencia	Stock	Mano	DCONMS	LF	WF	WF2	WT*2	Placas
H63TH-SVPBR-DX16*	●	R	63	65	45	3.8	1.1	VBOT/VBOW 1604○○
H63TH-SVPBL-DX16*	●	L	63	65	45	3.8	1.1	VBOT/VBOW 1604○○

1/1

1. Las dimensiones que se muestran son con placas de radio 0.8.



REPUESTOS

Placas				
	Placa base	Pasador de asiento	Tornillo	Llave
VBOT/VBOW	SPSVN32	BCP141	TS35D	TKY15F

* Las Herramientas marcadas en la tabla, no se pueden fijar en la Mazak INTEGREX I, J serie.

*1 Par de fijación (N • m): TS35D = 3.5

*2 WT: Peso de la herramienta

SVVB

REFRENTADO – COPIADO

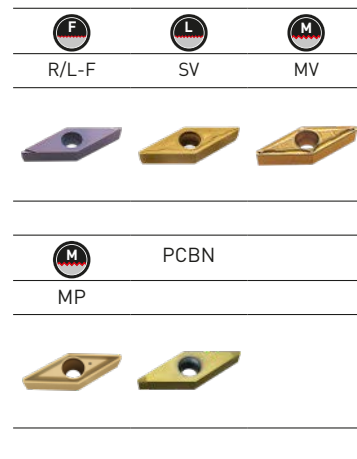
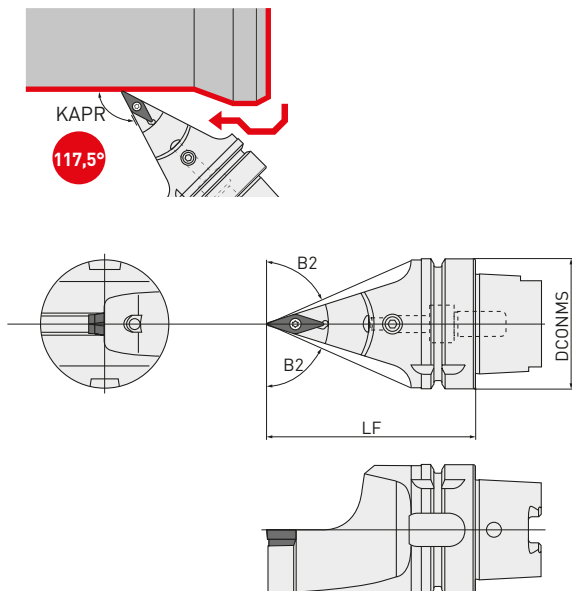





Referencia	Stock	DCONMS	LF	B2	WT*2	Placas
H63TH-SVVBN-H16	●	63	100	66.5°	1.3	VBOT/VBOW 1604○○
H63TH-SVVBN-L16	●	63	140	72.5°	2.2	

1/1

1. Las dimensiones que se muestran son con placas de radio 0.8.



REPUESTOS



Placas					
	Placa base	Pasador de asiento	Tornillo	Tapón	Llave
VBOT/VBOW	SPSVN32	BCP141	TS35D	HGM-PT1/8	TKY15F

*1 Par de fijación (N • m): TS35D = 3.5

*2 WT: Peso de la herramienta

CONDICIONES DE CORTE RECOMENDADAS

SVPB/SVVB

Material	Dureza		Calidad		Vc
P Acero dulce	≤180HB	F	AP25N	F	250 (150 – 300)
		M	MC6115	MP	250 (180 – 330)
Acero al carbono, Acero aleado	180 – 350HB	F	AP25N	F	210 (150 – 260)
		M	MC6125	MP	210 (160 – 260)
M Acero Inoxidable	≤200HB	M	MP7135	MM	100 (70 – 120)
K Fundición gris	Resistencia a la tracción < 350MPa	M	MC5115	MK	220 (160 – 290)

1/1

MG

RANURADO

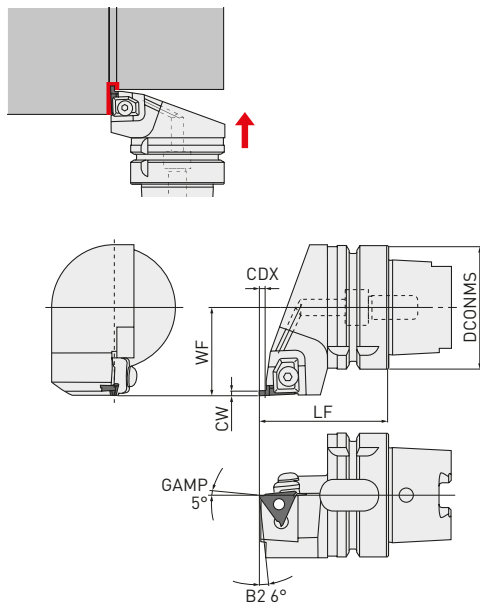

Se muestra el portaherramientas a mano derecha.





Referencia	Stock	Mano	DCONMS	CW	CDX	LF	WF	WT*2	Placas
H63TH-MGHR-DX4315*	★	R	63	1.25	1.2	65	45	1.2	
H63TH-MGHL-DX4315*	★	L	63	1.25	1.2	65	45	1.2	
H63TH-MGHR-DX4315*	★	R	63	1.45	1.5	65	45	1.2	
H63TH-MGHL-DX4315*	★	L	63	1.45	1.5	65	45	1.2	
H63TH-MGHR-DX4315*	★	R	63	1.5 < CW ≤ 2.3	3.0	65	45	1.2	MGTR/L 43125 - 43470
H63TH-MGHL-DX4315*	★	L	63	1.5 < CW ≤ 2.3	3.0	65	45	1.2	
H63TH-MGHR-DX4323*	★	R	63	2.3 < CW < 3.3	4.5	65	45	1.2	
H63TH-MGHL-DX4323*	★	L	63	2.3 < CW < 3.3	4.5	65	45	1.2	
H63TH-MGHR-DX4333*	★	R	63	3.3 < CW < 4.7	4.5	65	45	1.2	
H63TH-MGHL-DX4333*	★	L	63	3.3 < CW < 4.7	4.5	65	45	1.2	

1/1

(10 placas por caja)



REPUESTOS

Placas		 *1		
	Tornillo de fijación	Tornillo	Muelle	Llave
MGTR/L	MTK1R/L	HBH06020	MES3	HKY40R



* Las Herramientas marcadas en la tabla, no se pueden fijar en la Mazak INTEGREX I, J serie.

*1 Par de fijación (N • m): HBH06020 = 7.0

*2 WT: Peso de la herramienta

CONDICIONES DE CORTE RECOMENDADAS

MG

Material	Dureza	 	Calidad	Vc	f
P Acero al carbono, Acero aleado	180 – 350HB	F	VP20MF	120 (100 – 140)	0.10 (0.03 – 0.18)
		M	NX2525	130 (100 – 160)	0.12 (0.03 – 0.2)
M Acero Inoxidable	≤200HB	M	VP20MF	120 (100 – 140)	0.10 (0.03 – 0.18)
K Fundición gris	Resistencia a la tracción < 350MPa	M	VP20MF	120 (100 – 140)	0.10 (0.03 – 0.18)

1/1

PLACAS

Referencia	VP20MF		NX2525		UT120T		CW	CDX	IC	W1	RER/L	LE	Geometría
	R	L	R	L	R	L							
	MGTR/L43125	★	★	★	★	●							
MGTR/L43145	★	★		★	●	★	1.45	1.5	12.7	4.76	0.2	—	
MGTR/L43150	★	★	★	●	●	●	1.50	3.0	12.7	4.76	0.2	2.7	
MGTR/L43175	★	★	★	★	●	●	1.75	3.0	12.7	4.76	0.2	—	
MGTR/L43200	★	★	★	●	●	●	2.00	3.0	12.7	4.76	0.2	2.7	
MGTR/L43230	★	★	●	★	●	●	2.30	3.0	12.7	4.76	0.2	—	
MGTR/L43250	★	★	★	★	●	●	2.50	4.5	12.7	4.76	0.3	2.7	
MGTR/L43260	★	★	★		●	●	2.60	4.5	12.7	4.76	0.3	—	
MGTR/L43270	★	★			●	★	2.70	4.5	12.7	4.76	0.3	—	
MGTR/L43280		★		★	●	●	2.80	4.5	12.7	4.76	0.3	—	
MGTR/L43300	★	★	★	★	●	●	3.00	4.5	12.7	4.76	0.3	2.7	
MGTR/L43320	★				●	●	3.20	4.5	12.7	4.76	0.3	—	
MGTR/L43330		★		★	●	●	3.30	4.5	12.7	4.76	0.3	—	
MGTR/L43350	★	★	★	★	●	●	3.50	4.5	12.7	4.76	0.3	2.7	
MGTR/L43400	★	★	★		●	●	4.00	4.5	12.7	4.76	0.3	2.7	
MGTR/L43420	★	★	★		●	●	4.20	4.5	12.7	4.76	0.4	—	
MGTR/L43430	★	★	★		●	●	4.30	4.5	12.7	4.76	0.4	—	
MGTR/L43450	★	★	●	★	●	●	4.50	4.5	12.7	4.76	0.4	—	
MGTR/L43470	★	★	★	★	●	★	4.70	4.5	12.7	4.76	0.4	—	

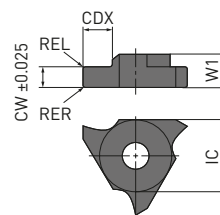

1/1

Se muestra el portaherramientas a mano derecha.

MMTE

ROSCADO

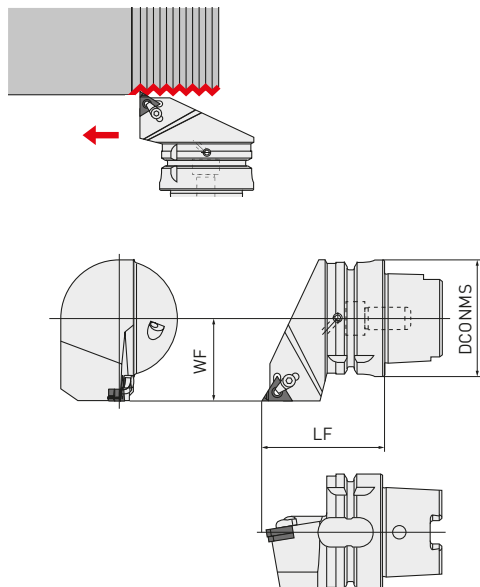





Solo herramienta a mano derecha.

Referencia	Stock	Mano	DCONMS	LF	WF	WT*2	Placas
H63TH-MMTER-DX16*	★	R	63	65	45	1.2	MMT16ER 

1/1



REPUESTOS

Insert number		 *1			 *1	
	Tornillo de fijación	Tornillo	Anillo tope	Placa base	Tornillo	Llave
MMT16ER	SETK51	SETS51	CR4	CTE32TP15	HFC03008	TKY15F/HKY20R

* Las Herramientas marcadas en la tabla, no se pueden fijar en la Mazak INTEGREX I, J serie.

*1 Par de fijación (N • m): SETS51 = 3.5, HFC03008 = 1.5

*2 WT: Peso de la herramienta

MMTEN

ROSCADO

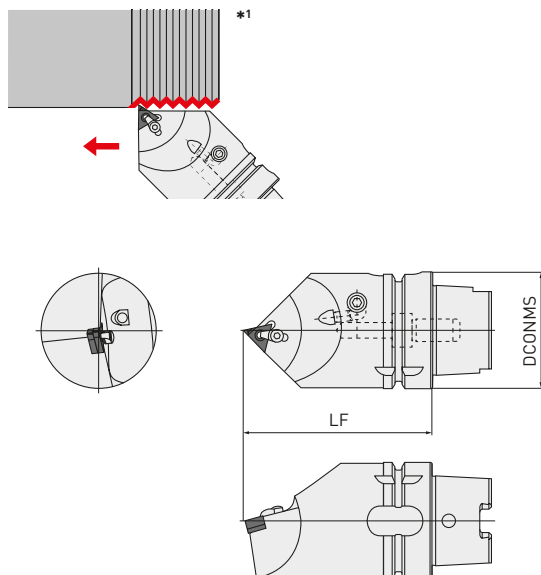

Solo herramienta con placa a mano derecha.

Referencia	Stock	DCONMS	LF	WT* ³	Placas
H63TH-MMTENR-H16	★	63	100	1.7	MMT16ER 
H63TH-MMTENR-L16	★	63	140	2.7	

1/1



REPUESTOS

Insert number	 Tornillo de fijación	 * ² Tornillo	 Anillo tope	 Placa base	 * ² Tornillo	 F R Llave
MMT16ER	SETK51	SETS51	CR4	CTE32TP15	HFC03008	TKY15F/HKY20R

*¹ Para utilizar con el eje B inclinado a 45°.

*² Par de fijación (N • m): SETS51 = 3.5, HFC03008 = 1.5

*³ WT: Peso de la herramienta

CONDICIONES DE CORTE RECOMENDADAS

MMTE/MMTEN

Material	Dureza	Calidad	Vc
P Acero dulce	≤180HB	MP9025	80 (60 – 100)
		VP10MF	150 (70 – 230)
		VP15TF	100 (60 – 140)
		VP20RT	80 (60 – 100)
Acero al carbono, Acero aleado	180 – 350HB	MP9025	80 (60 – 100)
		VP10MF	140 (80 – 200)
		VP15TF	100 (60 – 140)
M Acero Inoxidable	≤200HB	VP20RT	80 (60 – 100)
		MP9025	80 (40 – 120)
		VP15TF	80 (40 – 120)
K Fundición gris	Resistencia a la tracción < 350MPa	VP20RT	80 (40 – 120)
		VP10MF	140 (80 – 200)
		VP15TF	90 (60 – 120)

1/1

MT

ROSCADO

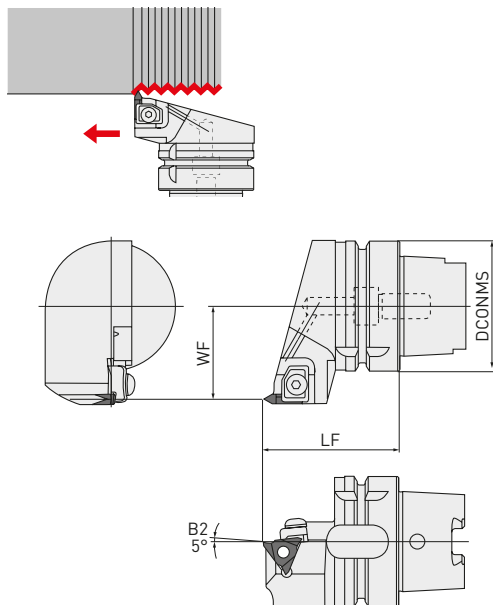





Se muestra el portaherramientas a mano derecha.

Referencia	Stock	Mano	DCONMS	LF	WF	WT*2	Placas
H63TH-MTHR-DX43*	★	R	63	65	45	1.2	MTTR/L 43○○○○
H63TH-MTHL-DX43*	★	L	63	65	45	1.2	

1/1



REPUESTOS

Placas		 *1		
	Tornillo de fijación	Tornillo	Muelle	Llave
MTTR/L	MTK1R/L	HBH06020	MES3	HKY40R

* Las Herramientas marcadas en la tabla, no se pueden fijar en la Mazak INTEGREX I, J serie.

*1 Par de fijación (N • m): HBH06020 = 7.0

*2 WT: Peso de la herramienta

CONDICIONES DE CORTE RECOMENDADAS

MT

Material	Dureza	Calidad	Vc
P Acero dulce	≤180HB	UP20M	140 (100 - 180)
		NX2525	200 (150 - 250)
		UTi20T	120 (100 - 150)
Acero al carbono, Acero aleado	180 - 350HB	UP20M	120 (100 - 150)
		NX2525	170 (150 - 200)
		UTi20T	100 (70 - 120)
M Acero Inoxidable	≤200HB	UP20M	120 (80 - 150)
		UTi20T	100 (70 - 130)
K Fundición gris	Resistencia a la tracción < 350MPa	UP20M	80 (60 - 100)
		UTi20T	80 (60 - 100)
		HTi10	100 (70 - 130)

1/1

INSERTOS DE ROSCADO

GENERAL 60°

Referencia	Clase	UP20M	NX2525	UTi20T	HTi10	ISO Paso mm (paso/rosca)	IC	W1	RE	Geometría
MTTR436000	G	●	●			- 0.8	12.7	4.76	0.0	
MTTR436001	G	★	●	●	★	1.0 - 1.75	12.7	4.76	0.1	
MTTL436001	G	★		●	★	1.0 - 1.75	12.7	4.76	0.1	
MTTR436002	G	★	●	●	★	2.0 - 2.5	12.7	4.76	0.2	
MTTL436002	G		●	●		2.0 - 2.5	12.7	4.76	0.2	
MTTR436003	G	★	●	●	★	3.0 - 3.5	12.7	4.76	0.3	
MTTL436003	G		●	●		3.0 - 3.5	12.7	4.76	0.3	
MTTR436004	G		●	●		4.0 - 4.5	12.7	4.76	0.4	

1/1

GENERAL 55°

Referencia	Clase	UP20M	NX2525	UTi20T	HTi10	ISO Paso mm (paso/rosca)	IC	W1	RE	Geometría
MTTR435501	G		●	●	★	28 - 10	12.7	4.76	0.1	
MTTR435502	G		●	●	●	16 - 8.0	12.7	4.76	0.2	
MTTR435503	G		●	●	●	11 - 8.0	12.7	4.76	0.3	

1/1

Se muestra el portaherramientas a mano derecha.

VALORES DE PROFUNDIDAD DE ROSCADO

MÉTRICA DE ROSCA

P	0.75	1.00	1.25	1.50	1.75	2.00	2.50	3.00	3.50	4.00	4.50	
h1	0.46	0.61	0.77	0.92	1.07	1.23	1.53	1.84	2.15	2.45	2.76	
h2	0.35	0.47	0.59	0.70	0.82	0.94	1.17	1.41	1.65	1.87	2.11	
r	0.11	0.14	0.18	0.22	0.25	0.29	0.36	0.43	0.50	0.58	0.65	
Número de Pasadas	1	0.18	0.20	0.20	0.25	0.25	0.25	0.30	0.30	0.35	0.35	0.40
	2	0.13	0.15	0.18	0.20	0.20	0.25	0.25	0.25	0.30	0.30	0.35
	3	0.10	0.10	0.12	0.15	0.20	0.20	0.20	0.25	0.25	0.25	0.30
	4	0.05	0.10	0.12	0.15	0.15	0.15	0.20	0.20	0.20	0.25	0.25
	5		0.06	0.10	0.10	0.12	0.15	0.15	0.20	0.20	0.25	0.25
	6			0.05	0.07	0.10	0.10	0.10	0.15	0.20	0.20	0.20
	7					0.05	0.08	0.10	0.15	0.15	0.20	0.20
	8						0.05	0.10	0.10	0.15	0.15	0.15
	9							0.08	0.10	0.10	0.15	0.15
	10								0.05	0.09	0.10	0.15
	11									0.05	0.10	0.10
	12										0.05	0.10
	13											0.05
	14											

1/1

1. La primera causa de alta carga en el filo.
Para evitar daños, mantenga la profundidad de corte entre 0.4 – 0.5mm máximo.

- La gráfica de la derecha muestra la profundidad de corte cuando se mecaniza en exterior en métrica ISO exterior.
- Cuando utilizamos en el corte calidades cermet ó acero inoxidable, por favor aumentar el número de pasadas, 2 ó 3 veces.

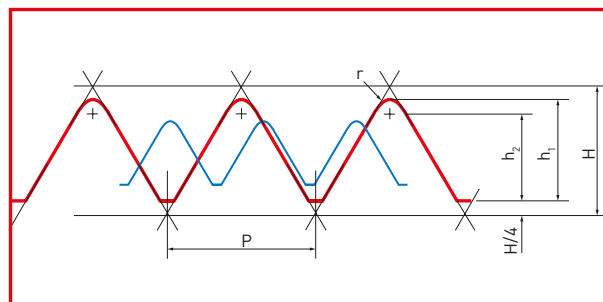

HERRAMIENTAS DE TORNEADO EXTERIOR

TORNEADO EXTERIOR – REFRENTADO

Esta herramienta es para una de tamaño de 25 x 25. Por favor cortar la herramienta como se muestra debajo, antes de usar.

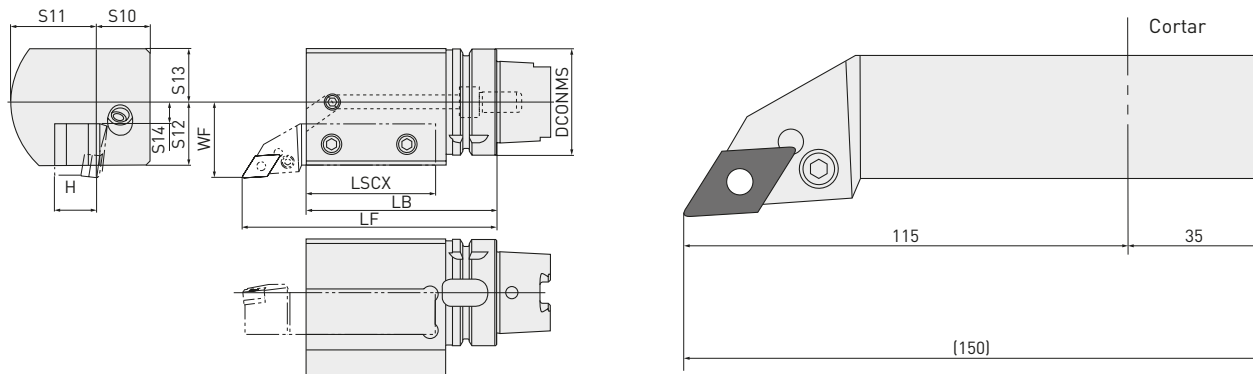



Se muestra el portaherramientas a mano derecha.

Referencia	Stock	Mano	DCONMS	LF	LB	LSCX	H	S10	S11	WF	S14	S12	S13	WT*1
H63TH-EV2525R-112*	★	R	63	150	112	77	25	32	53	45	13	38	32	3.9
H63TH-EV2525L-112*	★	L	63	150	112	77	25	32	53	45	13	38	32	3.9

1/1

REPUESTOS

Referencia		
	Tornillo	Tapón
H63TH-EV2525R/L-112	HSS12025	HGM-PT1/8

1. Pueden utilizarse con herramientas de 32 x 32 y 32 x 25. Posiblemente puede encajar una herramienta de 25 x 25 usando 7 mm de plato.

* Las Herramientas marcadas en la tabla, no se pueden fijar en la Mazak INTEGREX I, J serie.

*1 WT: Peso de la herramienta

HERRAMIENTAS DE TORNEADO EXTERIOR

TORNEADO EXTERIOR – REFRENTADO

Este portaherramientas es para herramientas de tamaños 32 x 32 y 32 x 25.

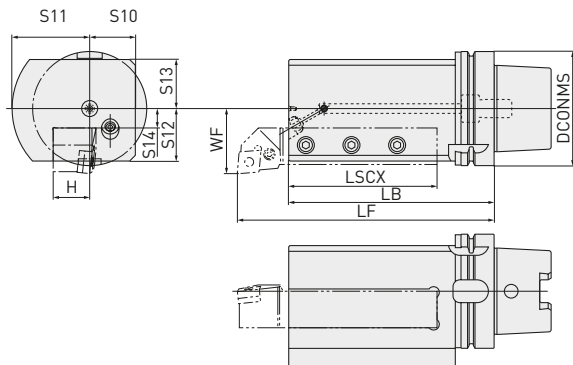



Se muestra el portaherramientas a mano derecha.

Referencia	Stock	Mano	DCONMS	LF	LB	LSCX	H	S10	S11	WF	S14	S12	S13	WT*1
H100TH-EV3232R-180*	★	R	100	220	180	130	32	40	68	57	17	46	43	11.7
H100TH-EV3232L-180*	★	L	100	220	180	130	32	40	68	57	17	46	43	11.7

1/1

REPUESTOS

Referencia		
	Tornillo	Tapón
H100TH-EV3232R/L-180	HSS14035	HSS06006

1. Pueden utilizarse con herramientas de 32 x 32 y 32 x 25. Posiblemente puede encajar una herramienta de 25 x 25 usando 7 mm de plato.

* Las Herramientas marcadas en la tabla, no se pueden fijar en la Mazak INTEGREG I, J serie.

*1 WT: Peso de la herramienta

HERRAMIENTAS DE TORNEADO EXTERIOR

TORNEADO EXTERIOR – REFRENTADO

Esta herramienta es para una de tamaño de 25 x 25. Por favor cortar la herramienta como se muestra debajo, antes de usar.

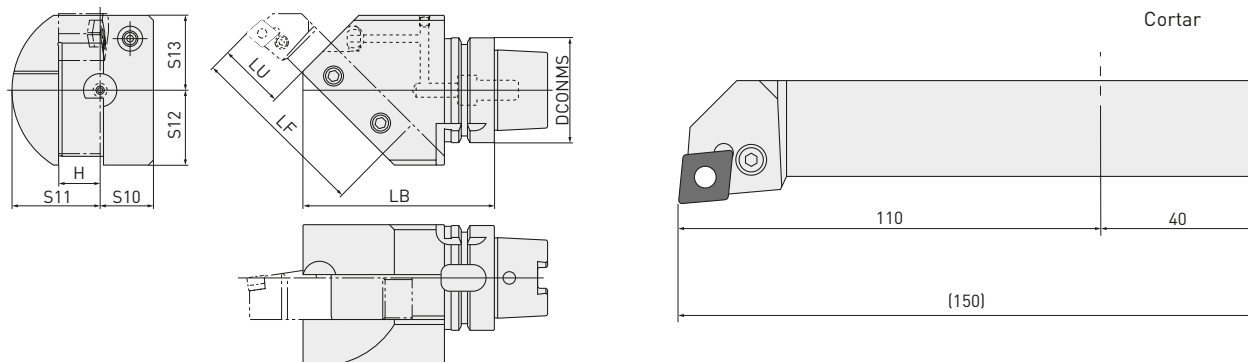



Se muestra el portaherramientas a mano derecha.

Mitsubishi Materials tiene licencia para la producción y distribución de estas herramientas de MORI SEIKI CO., LTD bajo la patente N° 3720202.

Referencia	Stock	Mano	DCONMS	LF	LU	LB	H	S10	S11	S12	S13	WT*1
H63TH-EN2525R-115*	★	R	63	110	40	115	25	32	53	45	45	3.7
H63TH-EN2525L-115*	★	L	63	110	40	115	25	32	53	45	45	3.7

1/1

REPUESTOS

Referencia		
	Tornillo	Tapón
H63TH-EN2525R/L-115	HSS12030	HSS06006

1. Pueden utilizarse con herramientas de 32 x 32 y 32 x 25. Posiblemente puede encajar una herramienta de 25 x 25 usando 7 mm de plato.

* Las Herramientas marcadas en la tabla, no se pueden fijar en la Mazak INTEGREX I, J serie.

*1 WT: Peso de la herramienta

HERRAMIENTAS DE TORNEADO EXTERIOR

TORNEADO EXTERIOR – REFRENTADO

Este portaherramientas es para herramientas de tamaños 32 x 32 y 32 x 25. Por favor cortar la herramienta como se muestra debajo, antes de usar.

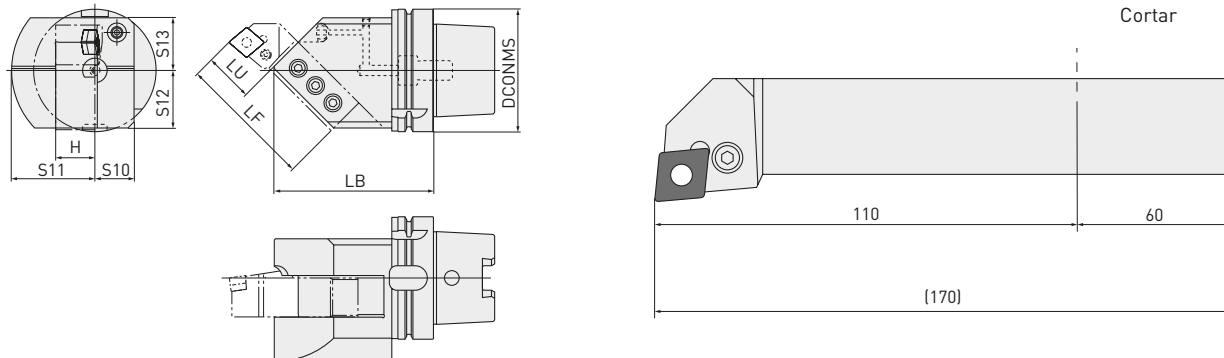



Se muestra el portaherramientas a mano derecha.

Mitsubishi Materials tiene licencia para la producción y distribución de estas herramientas de MORI SEIKI CO., LTD bajo la patente N° 3720202.

Referencia	Stock	Mano	DCONMS	LF	LU	LB	H	S10	S11	S12	S13	WT*1
H100TH-EN3232R-130*	★	R	100	110	40	130	32	32	68	47	43	6.6
H100TH-EN3232L-130*	★	L	100	110	40	130	32	32	68	47	43	6.6

1/1

REPUESTOS

Referencia		
	Tornillo	Tapón
H100TH-EN3232R/L-130	HSS14030	HSS06006

1. Pueden utilizarse con herramientas de 32 x 32 y 32 x 25. Posiblemente puede encajar una herramienta de 25 x 25 usando 7 mm de plato.

* Las Herramientas marcadas en la tabla, no se pueden fijar en la Mazak INTEGREX I, J serie.

*1 WT: Peso de la herramienta

HERRAMIENTAS DE TORNEADO EXTERIOR

TORNEADO EXTERIOR – REFRENTADO

Esta herramienta es para una de tamaño de 20 x 20. Por favor cortar la herramienta como se muestra debajo, antes de usar.

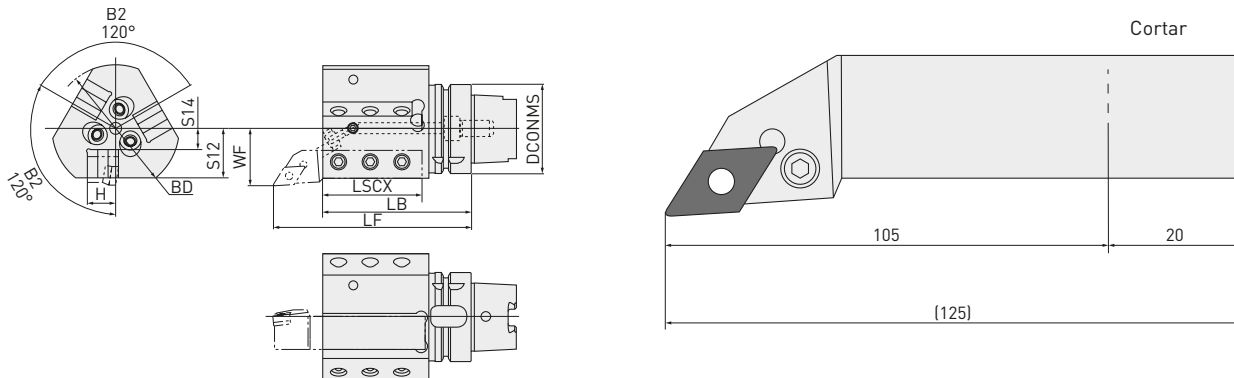



Se muestra el portaherramientas a mano derecha.

Referencia	Stock	Mano	DCONMS	LF	LSCX	H	BD	WF	S14	S12	WT*1
H63TH-EV2020R-105-3*	★	R	63	140	70	20	90	40	15	35	2.9
H63TH-EV2020L-105-3*	★	L	63	140	70	20	90	40	15	35	2.9

1/1

REPUESTOS

Referencia			
	Tornillo	Tapón	Tapón
H63TH-EV2020R/L-105-3	HSS12030	HSS05012	HSS06006

* Las Herramientas marcadas en la tabla, no se pueden fijar en la Mazak INTEGREX I, J serie.

*1 WT: Peso de la herramienta

BARRAS DE MANDRINAR

MANDRINADO

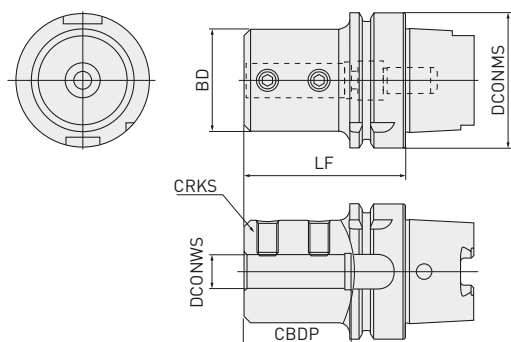

Referencia	Stock	DCONMS	BD	DCONWS	LF	CBDP	CRKS	WT*
H63TH-B08-65	★	63	28	8	65	40	M8	0.9
H63TH-B10-70	★	63	35	10	70	45	M8	1.0
H63TH-B12-70	★	63	42	12	70	45	M8	1.1
H63TH-B16-75	★	63	48	16	75	50	M10	1.3
H63TH-B20-75	★	63	52	20	75	50	M10	1.4
H63TH-B25-83	★	63	62	25	83	58	M12	1.7
H63TH-B32-87	★	63	62	32	87	62	M12	1.7
H63TH-B40-97	★	63	65	40	97	72	M16	1.8

1/1

REPUESTOS

Referencia	Tornillo
H63TH-B08-65	HSS08010
H63TH-B10-70	HSS08012
H63TH-B12-70	HSS08012
H63TH-B16-75	HSS10016
H63TH-B20-75	HSS10016
H63TH-B25-83	HSS12016
H63TH-B32-87	HSS12016
H63TH-B40-97	HSS16012

1. Por favor cortar la barra de mandrinar para ajustar a la longitud del mango. Esto tambien es aplicable para brocas de placa intercambiable.
 * WT: Peso de la herramienta

BARRAS DE MANDRINAR

MANDRINADO

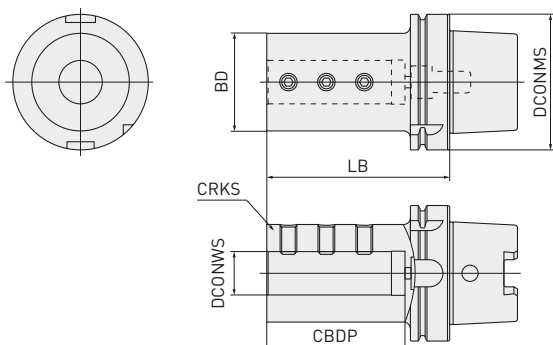

Referencia	Stock	DCONMS	BD	DCONWS	LB	CBDP	CRKS	WT*
H100TH-B25-120	★	100	62	25	120	88	M12	3.9
H100TH-B32-135	★	100	72	32	135	102	M12	4.8
H100TH-B40-150	★	100	82	40	150	117	M16	5.9
H100TH-B50-180	★	100	92	50	180	147	M16	7.7

1/1

REPUESTOS

Referencia	Tornillo
H100TH-B25-120	HSS12016
H100TH-B32-135	HSS12018
H100TH-B40-150	HSS16020
H100TH-B50-180	HSS16020

1. Disponible para usar con casquillo para la instalación de herramientas redondas pequeñas.

* WT: Peso de la herramienta

CASQUILLO PARA BARRA DE MANDRINAR

H100TH-B32-135

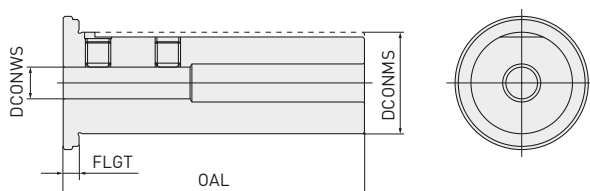

Referencia	Stock	DCONWS	DCONMS	OAL	FLGT	WT*
SL3208-90	★	8	32	95	5	0.6
SL3210-90	★	10	32	95	5	0.5
SL3212-90	★	12	32	95	5	0.5
SL3216-90	★	16	32	95	5	0.5
SL3220-90	★	20	32	95	5	0.4

1/1



























REPUESTOS

Referencia	Tornillo
SL3208-90	HSS06008
SL3210-90	HSS08008
SL3212-90	HSS08008
SL3216-90	HSS08006
SL3220-90	HSS08005

1. Estos casquillos solo son compatibles con herramientas H100TH-B32-135.

* WT: Peso de la herramienta

SÍMBOLOS

CONDICIONES DE CORTE RECOMENDADAS		TIPO DE CORTE	
	Condiciones de corte recomendadas		Desbaste
NEW	Productos o ampliaciones totalmente nuevos que se presentan en el lanzamiento actual (primavera u otoño) y que todavía no aparecen en el último catálogo general.		Corte medio
NEW	Productos o ampliaciones que se presentaron en ediciones de primavera y otoño anteriores y que aún no están en el último catálogo general.		Corte ligero
APLICACIÓN			Pre acabado
	Fresado planeado		Acabado
	Fresado de chaflanes		Acabado espejo
	Fresado escuadrado con radio	MATERIAL	
	Planeado cerca de la pared		Metal duro de ultra micro-grano El metal duro de ultra micro-grano se utiliza para las herramientas de corte.
	Fresado en escuadra		Nitruro de boro cúbico (CBN) Se utilizar el CBN original de Mitsubishi Materials.
	Fresado lateral		Cerámica Para un mecanizado eficiente a altas velocidades de super aleaciones , gracias a sus excelentes propiedades termorresistentes.
	Fresado ranurado		Pulvimetalurgia de alta dureza HSS Sustrato de pulvimetalurgia HSS de alta dureza.
	Fresado en rampa		HSS de aleación de alto grado Sustrato de aleacion de HSS de alto grado.
	Fresado de cajera		Acero rapido con cobalto Sustrato de acero rapido con aleacion de cobalto.
	Ranurado con radio		Acero rápido Sustrato de acero rápido.
	Fresado copiado		
	Fresado ranurado-T		

SÍMBOLOS

RECUBRIMIENTO



Recubrimiento SMART MIRACLE
Nueva tecnología de recubrimiento, densa y lisa de alta eficiencia para el mecanizado de materiales difíciles.



Recubrimiento CRN
Recubrimiento CrN recién desarrollado para el mecanizado de electrodos de cobre.



Recubrimiento VIOLET
Mejora la vida útil de la herramienta en 2-3 veces respecto a la de los productos de recubrimiento TiN.



Recubrimiento DP
Recubrimiento de nueva generación aplicable a un gran rango de materiales.



Recubrimiento MIRACLE
Recubrimiento original MIRACLE (Al,Ti)N. También apto para mecanizado en seco.



Recubrimiento (Al, Ti) N
(Al,Ti)N , con un alto rango de aplicación versátil.



Recubrimiento multicapa (Al,Ti,Cr)N
Ofrece mayor versatilidad para acero al carbono, acero aleado y acero endurecido.



Recubrimiento IMPACT MIRACLE
Recubrimiento monocapa con tecnología nano cristalina que genera una película dura y termorresistente.



Recubrimiento MIRACLE
Recubrimiento original (Al,Ti)N MIRACLE , también apto para mecanizado en seco.



Recubrimiento VFR
(AlCrS In / (AlTiStiN PVD recubrimiento multicapa) es ideal para mecanizar materiales extramadamente duros hasta 70 HRC.



Recubrimiento DLC
Dureza similar al recubrimiento de diamante CVD, logrando un recubrimiento con alta fuerza de adhesión.



Recubrimiento de diamante DFC
Para el mecanizado de materiales CFRP y CFRP con aluminio.



Recubrimiento de diamante DF
Aplicable para el mecanizado de grafito.



Recubrimiento de diamante
Recubrimiento de diamante CVD. Adecuado para el taladrado y fresado CFRP.



Recubrimiento de diamante CVD
Tecnología única multicapa que controla el posicionamiento de los micro granos de cristal de diamante , incrementando la resistencia al desgaste, y la suavidad en el recubrimiento.

CARACTERÍSTICAS



Filo vivo
Indica filo vivo de la fresa integral.



Superficie Gash
Indica que la fresa tiene un bisel de protección.



Ángulo de ataque o desprendimiento



Angulo de hélice
Indica el ángulo de la hélice de la ranura de la fresa integral.



Ángulo de la punta
Indica el ángulo de la broca en la punta. El ejemplo muestra 140°.



Hélice de desbaste



Hélice variable



Ranura de evacuación de viruta redondeada



90° KAPR **Ángulo de posición del filo de corte**

NÚCLEO DE LA BROCA



Tipo X
La reducción del núcleo X se utiliza en la punta de la broca.



Tipo XR
La reducción del núcleo XR se utiliza en el filo de corte de la broca.



Tipo S
Corte fácil. Mayor utilización.



Tipo N
Efectivo cuando el núcleo es ancho.



Rompevirutas

SÍMBOLOS

TOLERANCIA



Tolerancia del ángulo con conicidad

Indica la tolerancia del ángulo de filo en una fresa cónica.



Tolerancia R

Indica la tolerancia radial en las fresas esféricas.



Tolerancia R

Indica la tolerancia del radio en una fresa integral tórica.



Tolerancia R

Indica la tolerancia radial de una herramienta de corte con diente redondeado.



Tolerancia del diámetro exterior

Indica la tolerancia del diámetro de la fresa integral.



Tolerancia del filo de corte en la punta

Indica la tolerancia del diámetro en la punta.



h5

Tolerancia diámetro mango

Indica la tolerancia del diámetro del mango.



h6

Tolerancia diámetro mango

Indica la tolerancia del diámetro del mango.



Tolerancia de la broca / diámetro

AGUJERO DE REFRIGERACIÓN



Refrigerante externo



Refrigeración interna



Refrigeración interna



Centrado, agujero de refrigeración interna



Radial, agujero de refrigeración interna



Agujero de refrigeración interna



Agujero de refrigeración interna

RED DE VENTAS EUROPEA

GERMANY

MITSUBISHI MATERIALS TOOLS EUROPE GMBH
Comeniusstr. 2 . 40670 Meerbusch
Phone +49 2159 91890 . Fax +49 2159 918966
Email admin@mmchg.de

UK Office

MMC HARDMETAL UK LTD
1 Centurion Court, Centurion Way
Tamworth, B77 5PN
Phone +44 1827 312312
Email sales@mitsubishicarbide.co.uk

UK Deliveries / Returns

Unit 4 B5K Business Park, Quartz Close
Tamworth, B77 4GR

SPAIN

MITSUBISHI MATERIALS ESPAÑA, S.A.
Calle Emperador 2 . 46136 Museros / Valencia
Phone +34 96 1441711
Email comercial@mmevalencia.es

FRANCE

MMC METAL FRANCE S.A.R.L.
6, Rue Jacques Monod . 91400 Orsay
Phone +33 1 69 35 53 53 . Fax +33 1 69 35 53 50
Email mmfsales@mmc-metal-france.fr

POLAND

MMC HARDMETAL POLAND SP. Z O.O.
Al. Armii Krajowej 61 . 50-541 Wrocław
Phone +48 71335 1620 . Fax +48 71335 1621
Email sales@mitsubishicarbide.com.pl

ITALY

MMC ITALIA S.R.L.
Viale Certosa 144 . 20156 Milano
Phone +39 0293 77031 . Fax +39 0293 589093
Email info@mmc-italia.it

TURKEY

MITSUBISHI MATERIALS TOOLS EUROPE GMBH ALMANYA İZMİR MERKEZ ŞUBESİ
Adalet Mahallesi Anadolu Caddesi No: 41-1 . 15001 35530 Bayraklı / İzmir
Phone +90 232 5015000 . Fax +90 232 5015007
Email info@mmchg.com.tr

www.mmc-carbide.com

DISTRIBUIDO POR:

□

□

└

└

Publicado por:  MITSUBISHI MATERIALS TOOLS EUROPE